

# Babybett

Baby bed | Lit pour bébé | Lettino per neonati

## Montageanleitung

assembly instructions | instructions de montage |  
istruzioni di montaggio

*Ehrenkind*



## Lieferumfang prüfen

1. Nimm die Einzelteile aus der Verpackung.
2. Prüfe, ob die Lieferung vollständig ist.
3. Prüfe, ob das Produkt, die Einzelteile oder das Zubehör Schäden aufweisen. Ist dies der Fall, benutze das Produkt nicht. Wende dich direkt an uns über das Serviceportal.

- 1 2× Kopfteil/Fußteil
- 2 2× Seitenteil
- 3 1× Lattenrost
- 4 2× Seitenleiste
- 5 8× Schraube
- 6 8× Quermutter
- 7 4× Holzdübel
- 8 4× Hülsenmutter
- 9 4× Befestigungswinkel
- 10 1× Inbusschlüssel

Bitte beachte die Hinweise in der Montageanleitung!



---

## Checking scope of delivery

1. Take the individual components out of the packaging.
2. Check whether the delivery is complete.
3. Check whether the product, the individual components or accessories are damaged. If this is the case, do not use the product. Contact us directly via our service portal.

- 1 2× headboard/footboard
- 2 2× side part
- 3 1× slatted frame
- 4 2× side rail
- 5 8× screw
- 6 8× cross nut
- 7 4× wooden dowel
- 8 4× sleeve nut
- 9 4× mounting bracket
- 10 1× allen key

Please note the information in the assembly instructions!

## Vérification du contenu de la livraison

1. Sortez les différentes pièces de l'emballage.
2. Vérifiez si la livraison est complète.
3. Vérifiez si le produit, les pièces détachées ou les accessoires présentent des dommages. Si tel est le cas, n'utilisez pas le produit. Contactez-nous directement via notre portail de services.

- 1 2× Tête de lit / Pied de lit
- 2 2× Partie latérale
- 3 1× Sommier
- 4 2× Barre latérale
- 5 8× Vis
- 6 8× Écrou transversal
- 7 4× Cheville en bois
- 8 4× Équerre à visser
- 9 4× Équerre de fixation
- 10 1× Clé Allen



Veuillez tenir compte des indications dans les instructions de montage !

---

## Controllo della fornitura

1. Estrarre le singole parti dall'imballaggio.
2. Controllare che la fornitura sia completa.
3. Controllare se il prodotto, le singole parti o gli accessori sono danneggiati. In tale eventualità, non utilizzare il prodotto. Contattaci direttamente tramite il nostro portale di servizi.

- 1 2× Testiera / Pediera
- 2 2× Parte laterale
- 3 1× Telaio a doghe
- 4 2× Barra laterale
- 5 8× Vite
- 6 8× Dado trasversale
- 7 4× Tasselli di legno
- 8 4× Angolo di avvitaamento
- 9 4× Staffa di supporto
- 10 1× Chiave a brugola

Si prega di osservare nelle indicazioni istruzioni di montaggio!

**Babybett montieren**  
**Assembling the baby bed**

**Assemblage du lit pour bébé**  
**Montaggio del lettino per neonati**

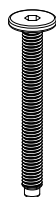
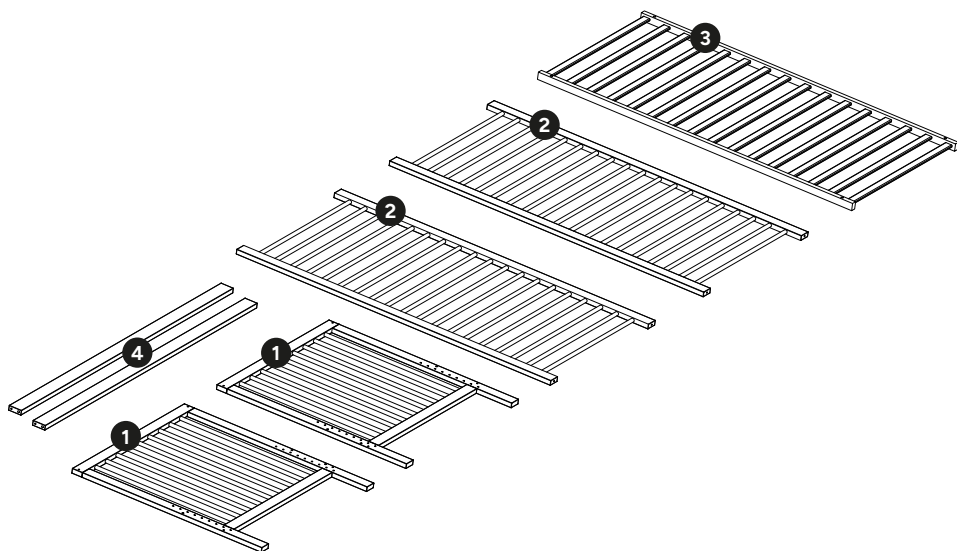

x8

5



x8

6



x4

7



x4

8



x4

9

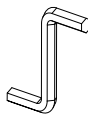

x1

10

Das Babybett bietet 3 verschiedene Aufbauvarianten.

Le lit pour bébé offre 3 variantes de construction différentes.

The baby bed offers 3 different assembly variants.

Il lettino per neonati offre 3 diverse varianti di montaggio.

A

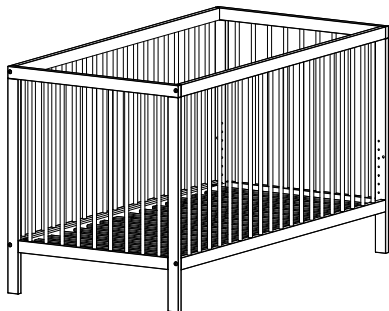

B

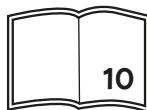
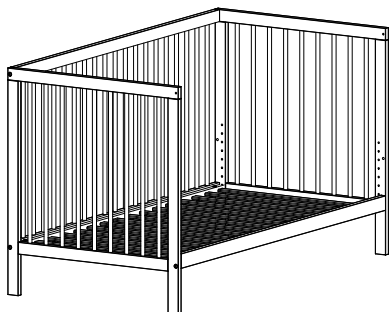

C

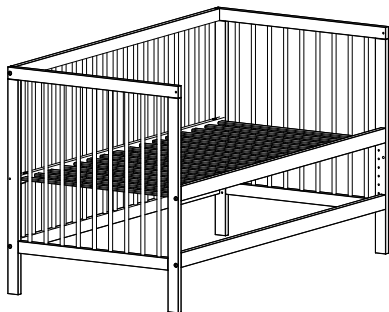

A

01

1 × 1    4 × 5  
2 × 2    4 × 6

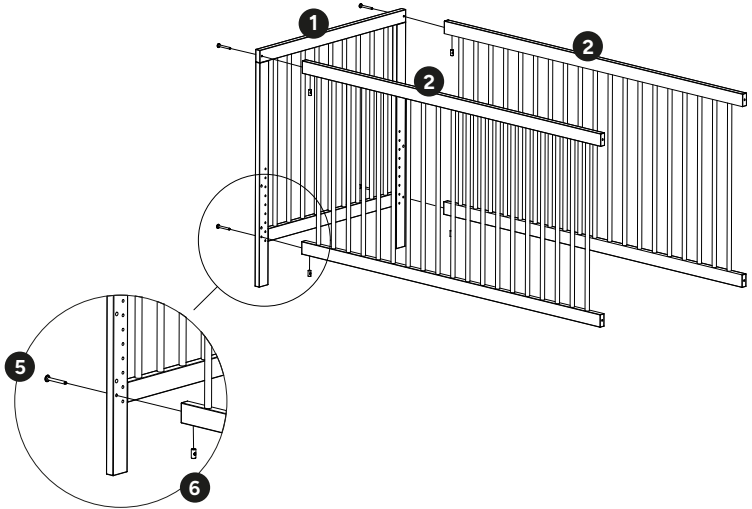

02

1 × 3    4 × 9  
4 × 8

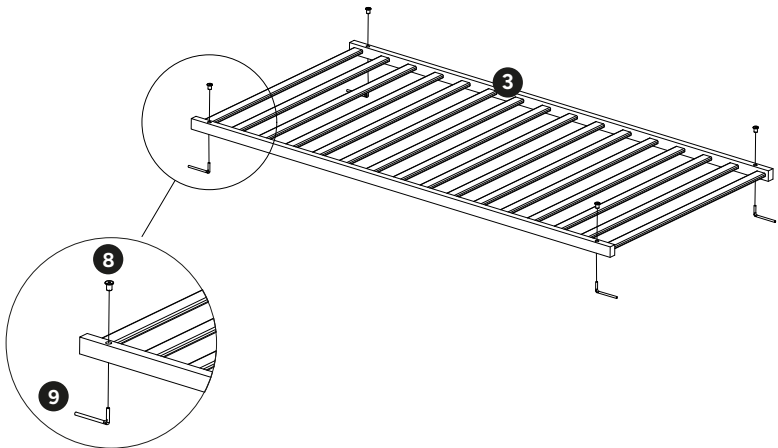

03

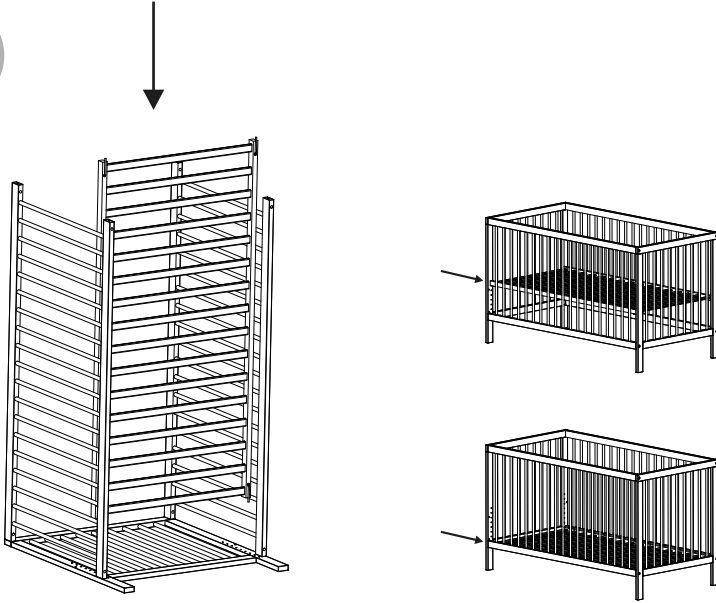

04

1 × 1  
4 × 5

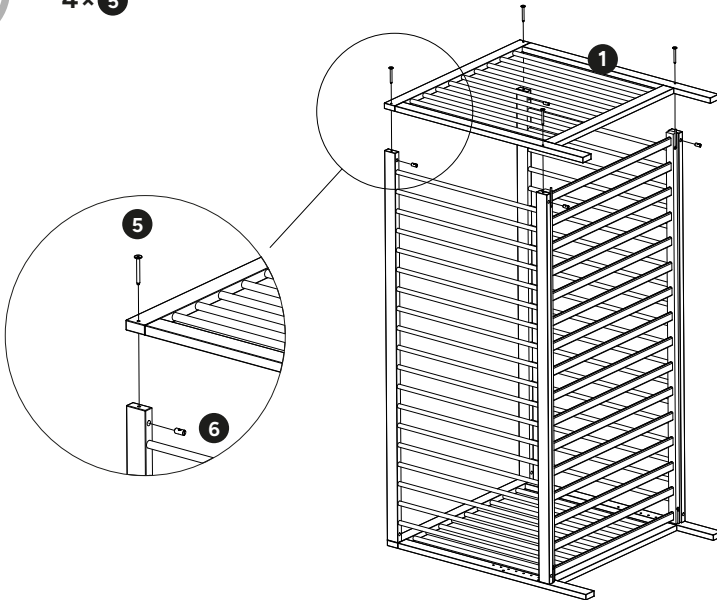



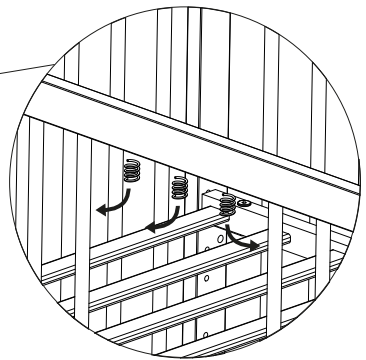
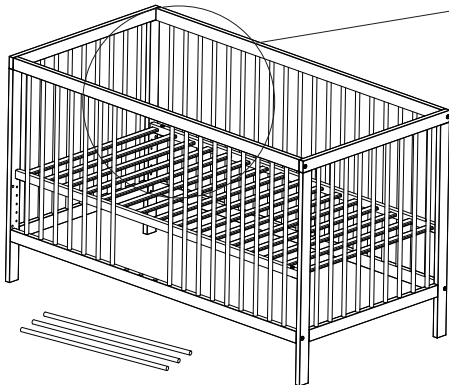
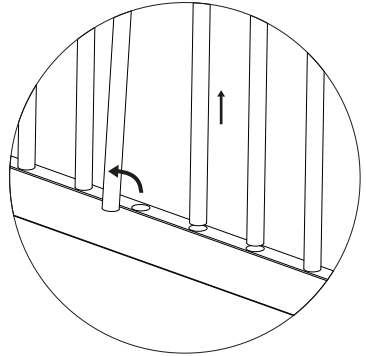
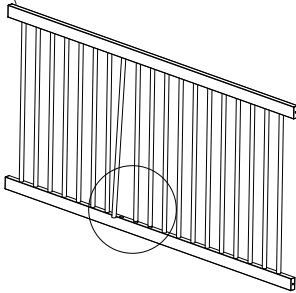
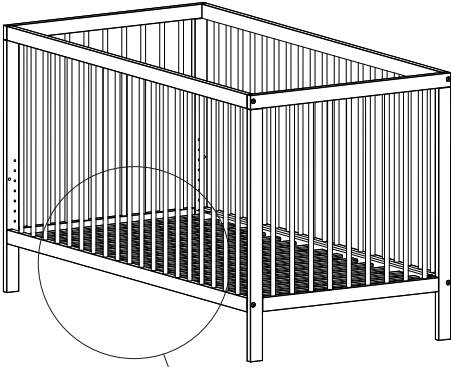

**B**

**01**

- 1× 1
- 1× 2
- 1× 4
- 3× 5
- 3× 6
- 1× 7

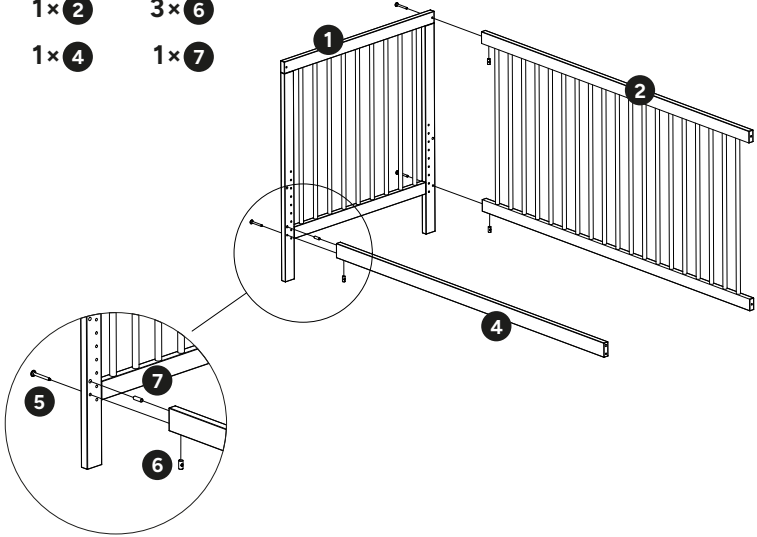

**02**

- 1× 3
- 4× 8
- 4× 9

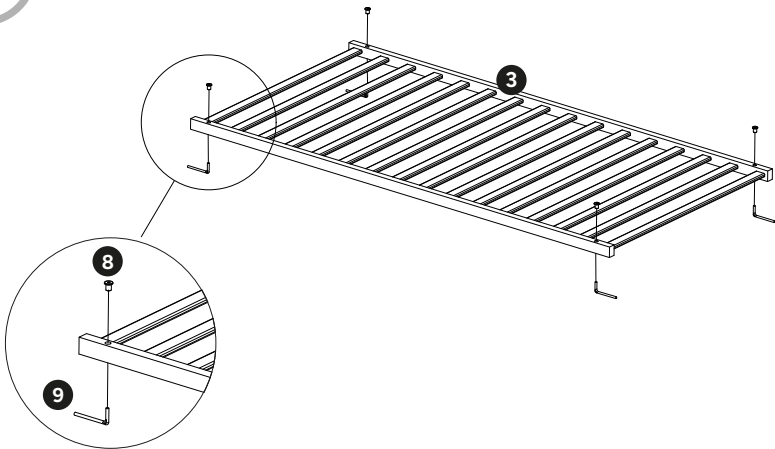

03

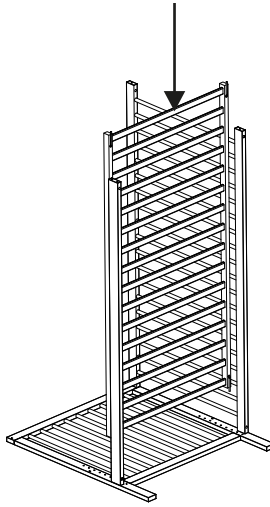

04

1× 1

3× 6

3× 5

1× 7

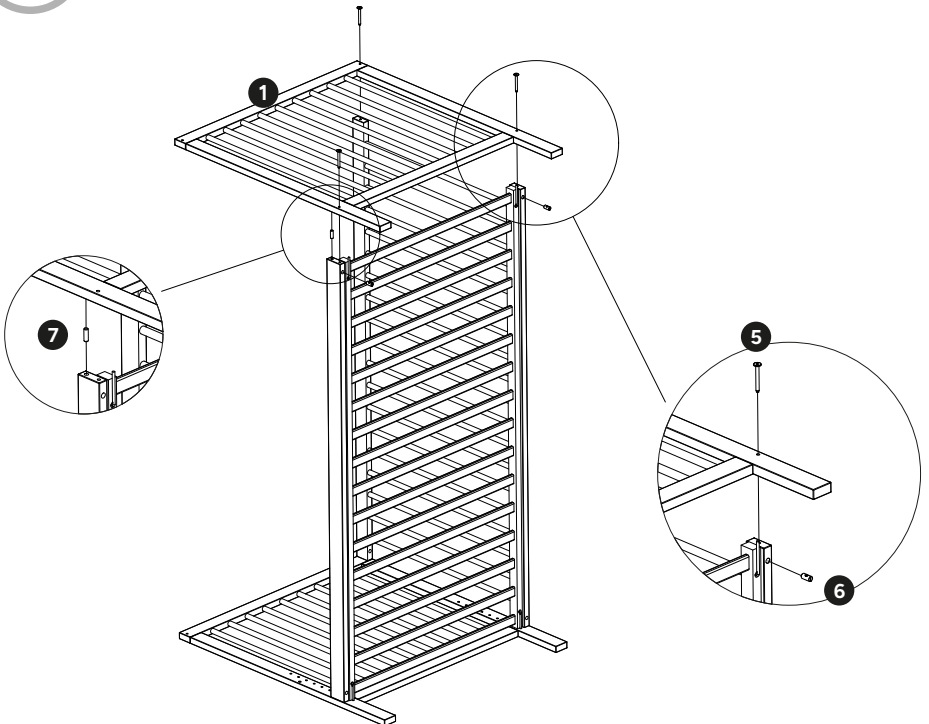

C

01

- 1 × 1
- 4 × 5
- 1 × 2
- 4 × 6
- 2 × 4
- 2 × 7

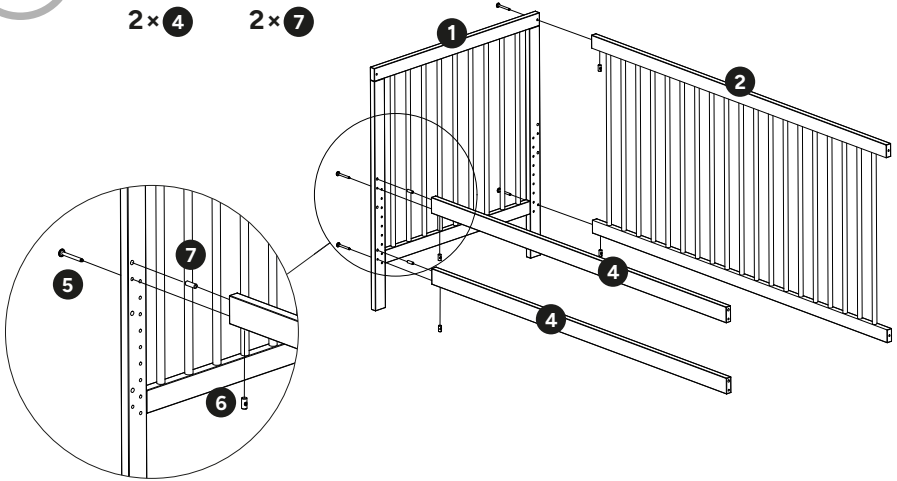

02

- 1 × 3
- 4 × 9
- 4 × 8

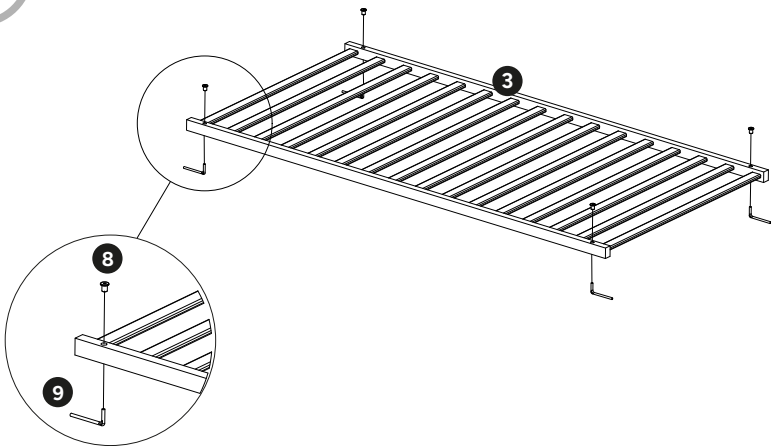

03

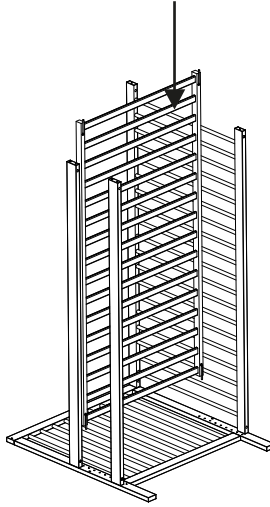

04

- 1 × 1
- 4 × 6
- 4 × 5
- 2 × 7

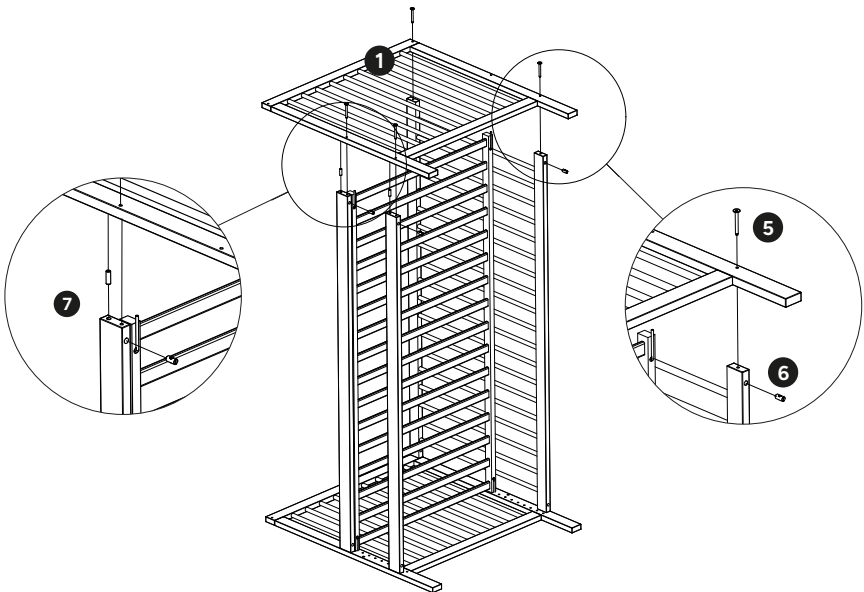

# Ehrenkind

## **Du brauchst Unterstützung?**

Besuche unser Serviceportal, scanne einfach den Code mit deinem Smartphone.

---

## **Need support?**

Visit our service portal, simply scan the code with your smartphone.



## **Ehrenkind**

formbench GmbH  
Ginsterweg 3  
74523 Schwäbisch Hall