

# Umbau-Set Familienbett Kiefer

Conversion kit Family Bed | Kit de transformation Lit familial |  
Kit di conversione Letto familiare

## Montageanleitung

assembly instructions | instructions de montage |  
istruzioni di montaggio

**Ehrenkind**



## Lieferumfang prüfen

1. Nimm die Einzelteile aus der Verpackung.
2. Prüfe, ob die Lieferung vollständig ist.
3. Prüfe, ob das Produkt, die Einzelteile oder das Zubehör Schäden aufweisen. Ist dies der Fall, benutze das Produkt nicht. Wende dich direkt an uns über das Serviceportal.

Bitte beachte die Hinweise in der Montageanleitung!

## Umbau-Set:

### Bodentief → Standardhöhe

- 5a Bein Fußteil links
- 6a Bein Fußteil rechts
- 7a Bein Kopfteil links
- 8a Bein Kopfteil rechts
- 9a Bein Fußteil mitte
- 10a Bein Kopfteil mitte
- C Holzdübel 12 × 50
- D Holzdübel 8 × 35
- H Holzschraube 5 × 60
- J Holzschraube 4 × 35
- U Filz 70 × 25
- X Inbusschlüssel 8 mm

## Umbau-Set:

### Standardhöhe → Bodentief

- 5b Bein Fußteil links
- 6b Bein Fußteil rechts
- 7b Bein Kopfteil links
- 8b Bein Kopfteil rechts
- 9b Bein Fußteil mitte
- 10b Bein Kopfteil mitte
- C Holzdübel 12 × 50
- D Holzdübel 8 × 35
- H Holzschraube 5 × 60
- J Holzschraube 4 × 35
- U Filz 70 × 25
- X Inbusschlüssel 8 mm



## Checking scope of delivery

1. Take the individual components out of the packaging.
2. Check whether the delivery is complete.
3. Check whether the product, the individual components or accessories are damaged. If this is the case, do not use the product. Contact us directly via our service portal.

Please note the information in the assembly instructions!

## Conversion kit:

### Floor-level → Standard

- 5a leg foodboard left
- 6a leg foodboard right
- 7a leg headboard left
- 8a leg headboard right
- 9a leg foodboard center
- 10a leg headboard center
- C wooden dowel 12 × 50
- D wooden dowel 8 × 35
- H wood screw 5 × 60
- J wood screw 4 × 35
- U felt 70 × 25
- X allen key 8 mm

## Conversion kit:

### Standard → Floor-level

- 5b leg foodboard left
- 6b leg foodboard right
- 7b leg headboard left
- 8b leg headboard right
- 9b leg foodboard center
- 10b leg headboard center
- C wooden dowel 12 × 50
- D wooden dowel 8 × 35
- H wood screw 5 × 60
- J wood screw 4 × 35
- U felt 70 × 25
- X allen key 8 mm



## Vérification du contenu de la livraison

1. Sortez les différentes pièces de l'emballage.
2. Vérifiez si la livraison est complète.
3. Vérifiez si le produit, les pièces détachées ou les accessoires présentent des dommages. Si tel est le cas, n'utilisez pas le produit. Contactez-nous directement via notre portail de services.

Veuillez tenir compte des indications dans les instructions de montage !

## Kit de transformation:

Niveau du sol → Standard

- 5a jambe pied de lit gauche
- 6a jambe pied de lit droite
- 7a jambe tête de lit gauche
- 8a jambe tête de lit droite
- 9a jambe pied de lit centre
- 10a jambe tête de lit centre
- C cheville en bois 12×50
- D cheville en bois 8×35
- H vis à bois 5×60
- J vis à bois 4×35
- U feutre 70×25
- X clé Allen 8 mm

## Kit de transformation:

Standard → Niveau du sol

- 5b jambe pied de lit gauche
- 6b jambe pied de lit droite
- 7b jambe tête de lit gauche
- 8b jambe tête de lit droite
- 9b jambe pied de lit centre
- 10b jambe tête de lit centre
- C cheville en bois 12×50
- D cheville en bois 8×35
- H vis à bois 5×60
- J vis à bois 4×35
- U feutre 70×25
- X clé Allen 8 mm



## Controllo della fornitura

1. Estrarre le singole parti dall'imballaggio.
2. Controllare che la fornitura sia completa.
3. Controllare se il prodotto, le singole parti o gli accessori sono danneggiati. In tale eventualità, non utilizzare il prodotto. Contattaci direttamente tramite il nostro portale di servizi.

Si prega di osservare nelle indicazioni istruzioni di montaggio!

## Kit di conversione:

### Profondità pavimento → Standard

- 5a gamba pediera sinistra
- 6a gamba pediera destra
- 7a gamba pannello testata sinistra
- 8a gamba pannello testata destra
- 9a gamba pediera centro
- 10a gamba pannello testata centro
- C tasselli di legno 12×50
- D tasselli di legno 8×35
- H viti per legno 5×60
- J viti per legno 4×35
- U sentito 70×25
- X chiave a brugola 8 mm

## Kit di conversione:

### Standard → Profondità pavimento

- 5b gamba pediera sinistra
- 6b gamba pediera destra
- 7b gamba pannello testata sinistra
- 8b gamba pannello testata destra
- 9b gamba pediera centro
- 10b gamba pannello testata centro
- C tasselli di legno 12×50
- D tasselli di legno 8×35
- H viti per legno 5×60
- J viti per legno 4×35
- U sentito 70×25
- X chiave a brugola 8 mm



**Familienbett montieren**  
**Assembling the family bed**

**Assemblage du lit familial**  
**Montaggio del letto familiare**

**Umbau-Set:**  
**Bodentief → Standardhöhe**

**Kit de transformation:**  
**Niveau du sol → Standard**

**Conversion kit:**  
**Floor-level → Standard**

**Kit di conversione:**  
**Profondità pavimento → Standard**

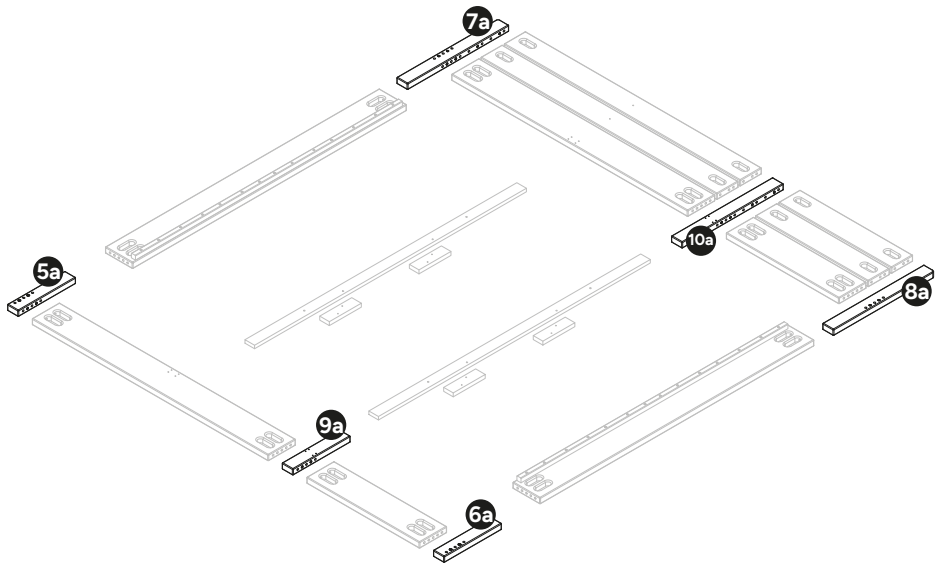

**C** **D** **H** **J** **U** **X**

**Familienbett montieren**  
**Assembling the family bed**

**Umbau-Set:**  
**Standardhöhe → Bodentief**

**Conversion kit:**  
**Standard → Floor-level**

**Assemblage du lit familial**  
**Montaggio del letto familiare**

**Kit de transformation:**  
**Standard → Niveau du sol**

**Kit di conversione:**  
**Standard → Profondità pavimento**

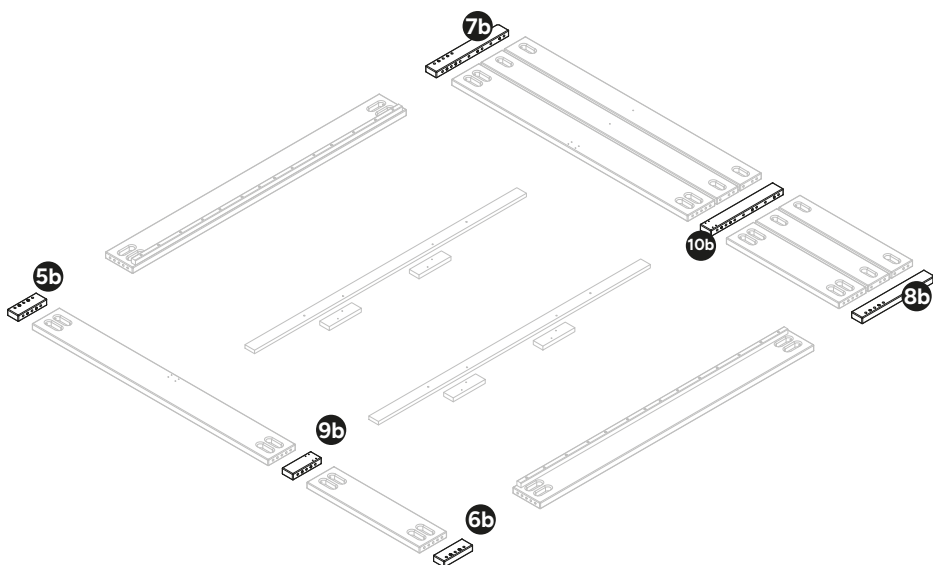

**C** **D** **H** **J** **U** **X**



01

Für den Umbau musst du zuerst dein bestehendes Bett zerlegen. Löse die Ablage am Kopfteil (falls vorhanden).

To convert your existing bed, you must first dismantle it. Detach the shelf at the headboard (if present).

Pour la transformation, tu dois d'abord démonter ton lit existant. Détache la tablette de la tête de lit (si elle existe).

Per convertire il letto esistente, è necessario prima smontarlo. Staccare il ripiano della testata (se presente).

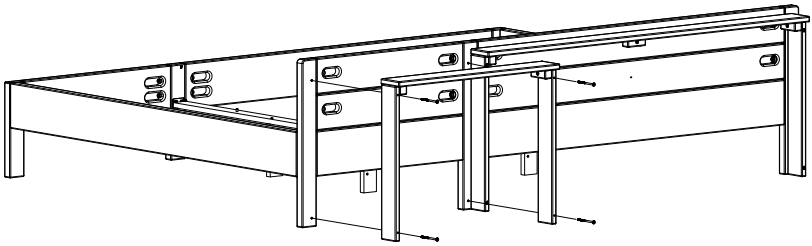

02

Nimm den Mittelbalken heraus.

Remove the centre bar.

Retire la barre centrale.

Rimuovere la barra centrale.

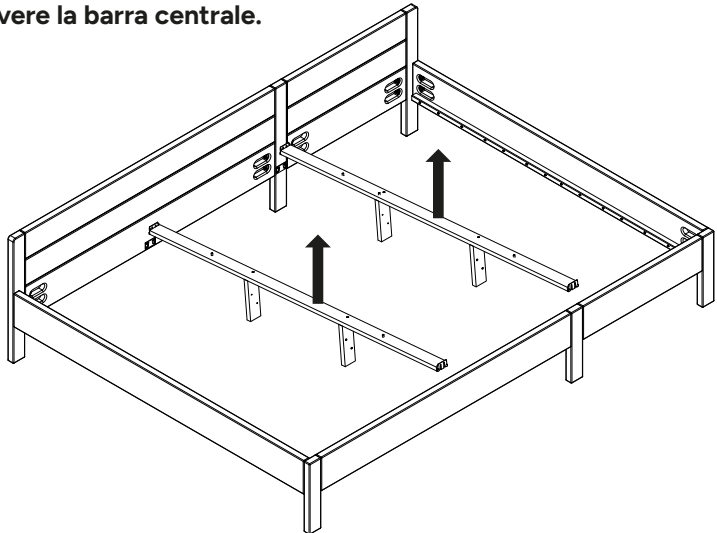

03

Löse die Schraubverbindungen der Posten zum Seitenteil und zerlege das Bett.

Loosen the screw connections of the posts to the side panel and dismantle the bed.

Dévisse les raccords vissés des postes au panneau latéral et démonte le lit.

Allentare i collegamenti a vite dei montanti al pannello laterale e smontare il letto.

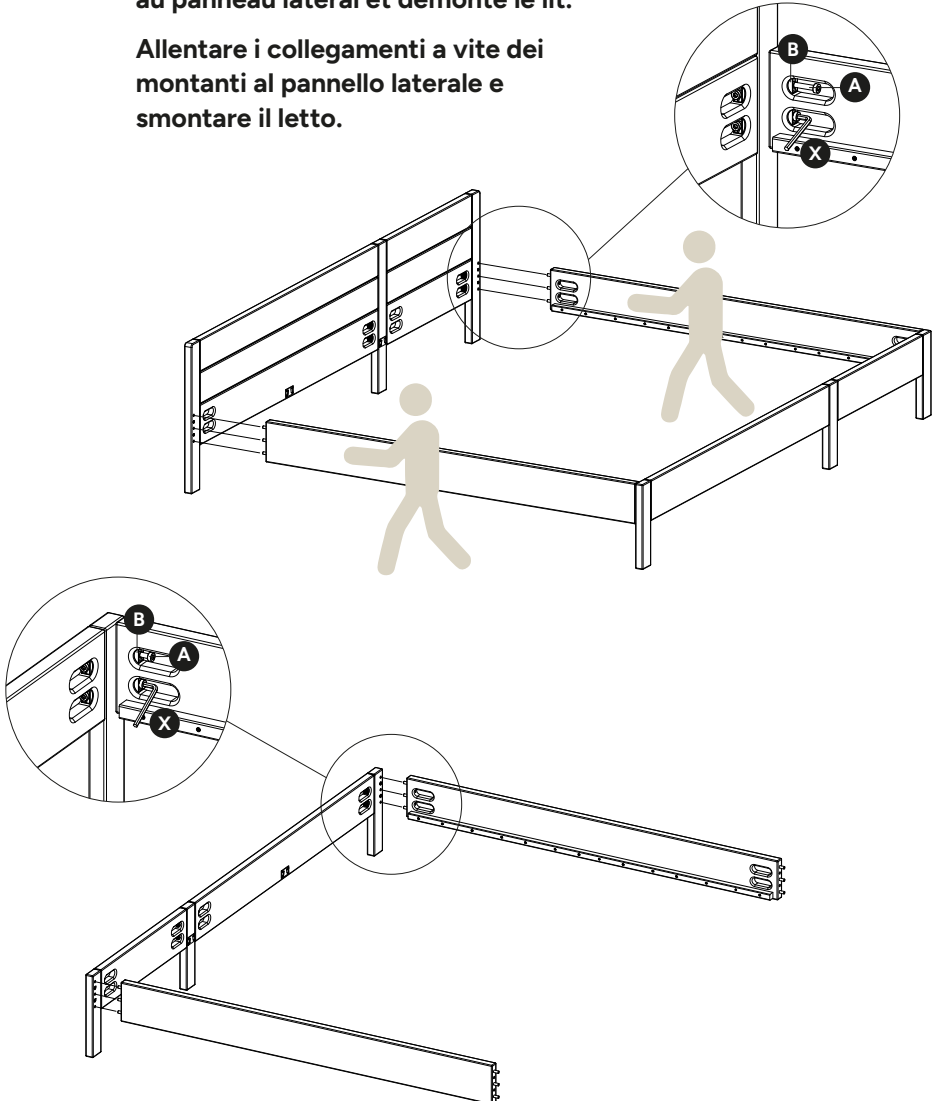

04

Löse nun die Schraubverbindungen am Kopfteil und tausche die Posten entsprechend aus.

Now loosen the screw connections on the head section and replace the items accordingly.

Dévisse maintenant les raccords à vis de la tête de lit et remplace les postes en conséquence.

Allentare ora i collegamenti a vite sulla sezione della testa e sostituire gli elementi di conseguenza.

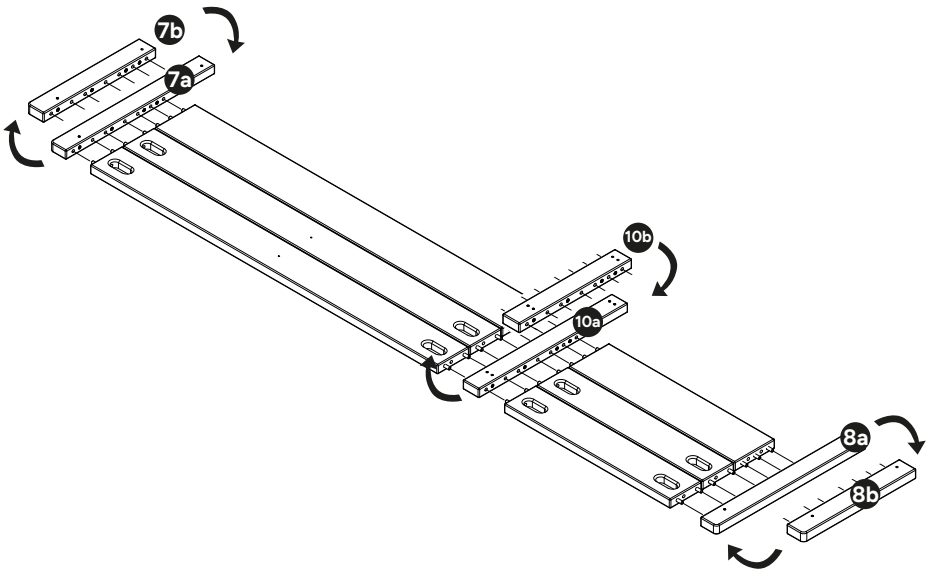

05

Löse nun die Schraubverbindungen am Fußteil und tausche die Posten entsprechend aus.

Now loosen the screw connections on the foot section and replace the items accordingly.

Dévisse maintenant les raccords à vis de la partie pied et remplace les postes en conséquence.

A questo punto, allentare i collegamenti a vite sulla sezione del piede e sostituire gli elementi di conseguenza.

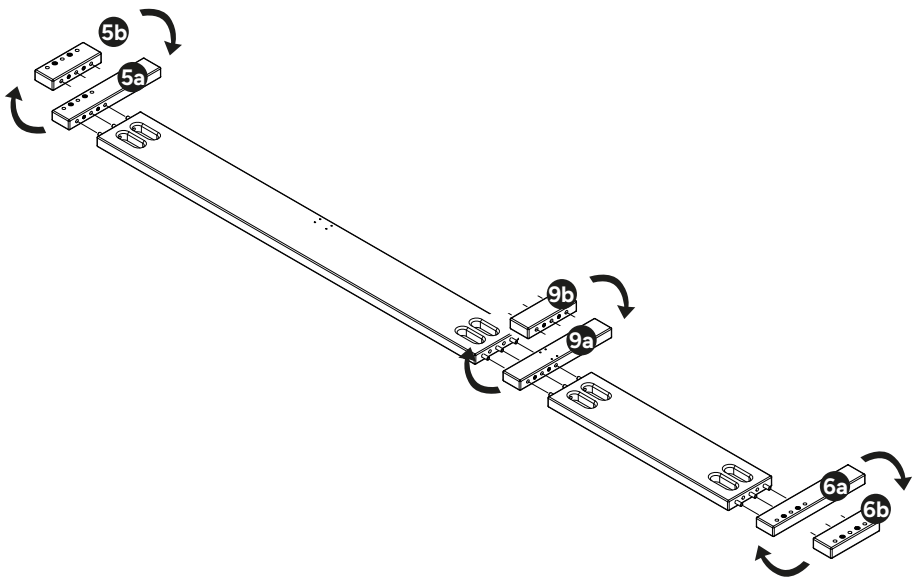

06

Die Seitenteile wieder mit dem Fuß- und Kopfteil verbinden.

Reconnect the side sections to the foot and head sections.

Relier à nouveau les parties latérales au pied et à la tête de lit.

Ricollegare le sezioni laterali alle sezioni dei piedi e della testa.

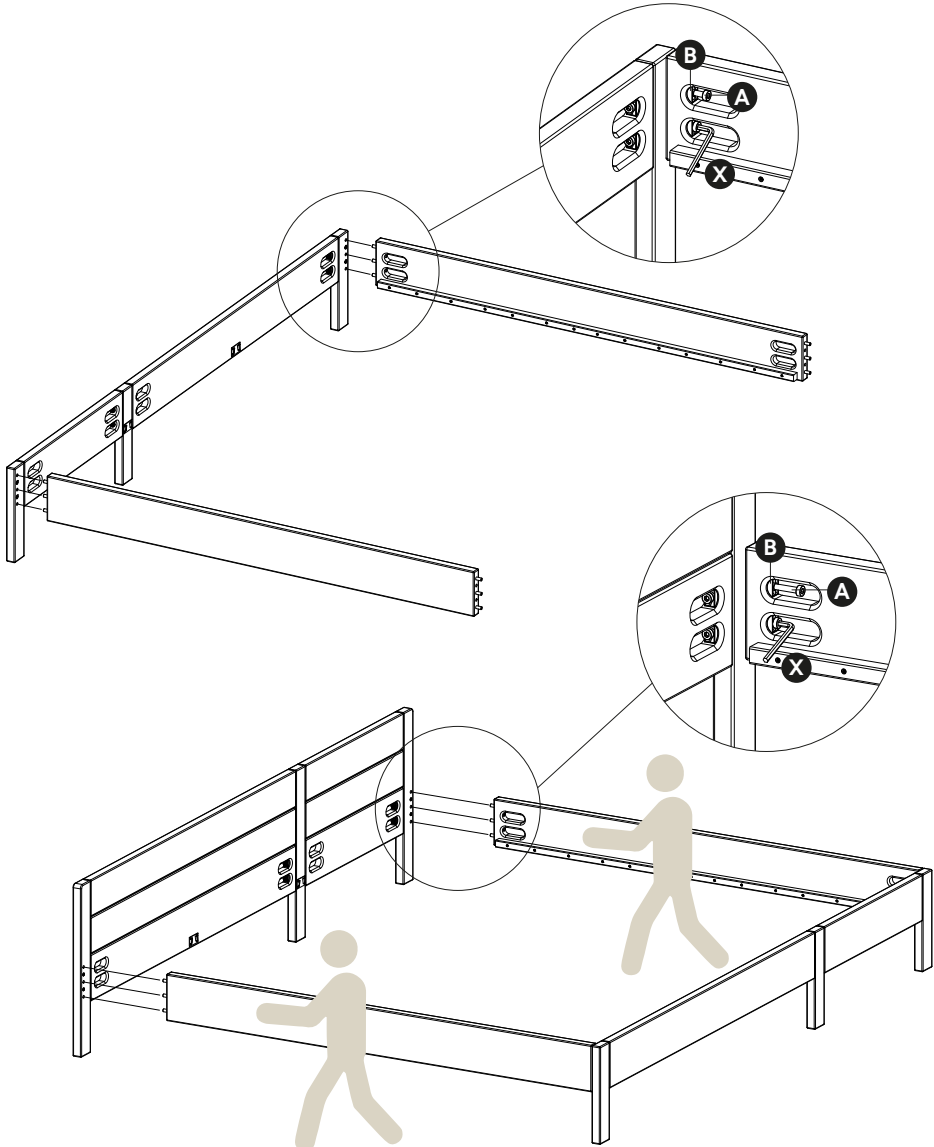

07

**Umbau Mittelbalken: Verschraubung der Beine vom Mittelbalken lösen und in neuer Position wieder befestigen. Auf Verwendung der richtigen Montageteile achten!**

**Converting the centre bar: Unscrew the screw connection of the legs from the centre bar and reattach in the new position. Ensure that the correct assembly parts are used!**

**Transformation de la poutre centrale : dévisser les pieds de la poutre centrale et les fixer dans une nouvelle position. Veiller à utiliser les bonnes pièces de montage !**

**Conversione della barra centrale: svitare il collegamento a vite delle gambe dalla barra centrale e riattaccarlo nella nuova posizione. Assicurarsi di utilizzare le parti di montaggio corrette!**

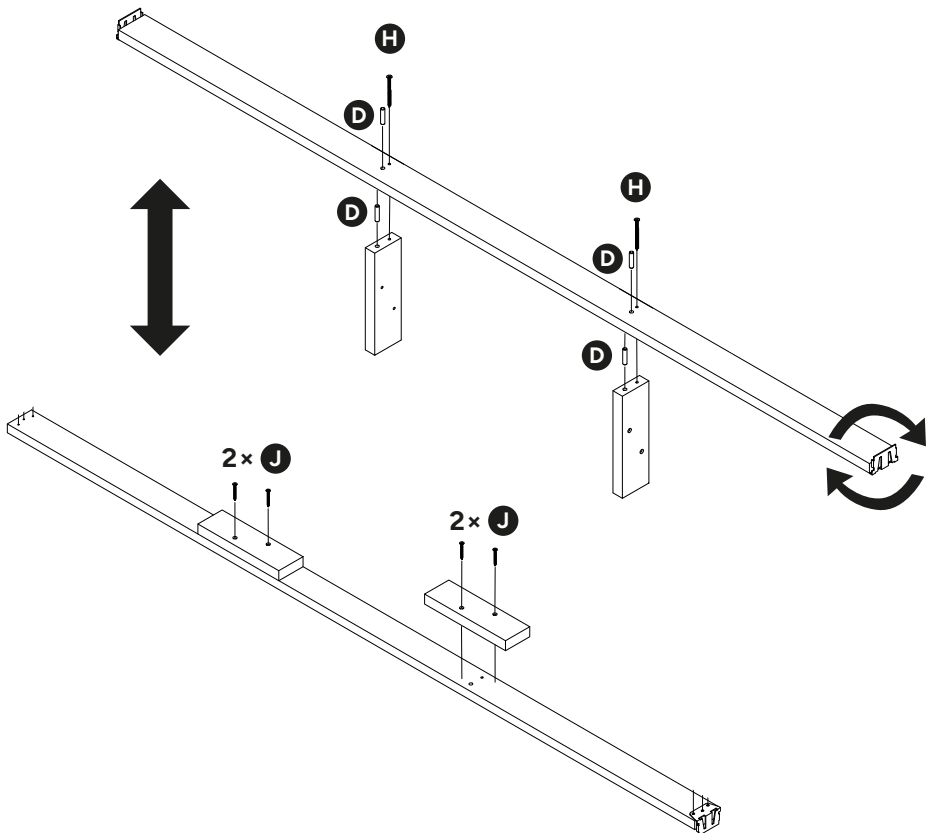

08

Setze die Mittelbalken wieder ein.

Replace the centre bar.

Remets les barres centrales en place.

Sostituire la barra centrale.

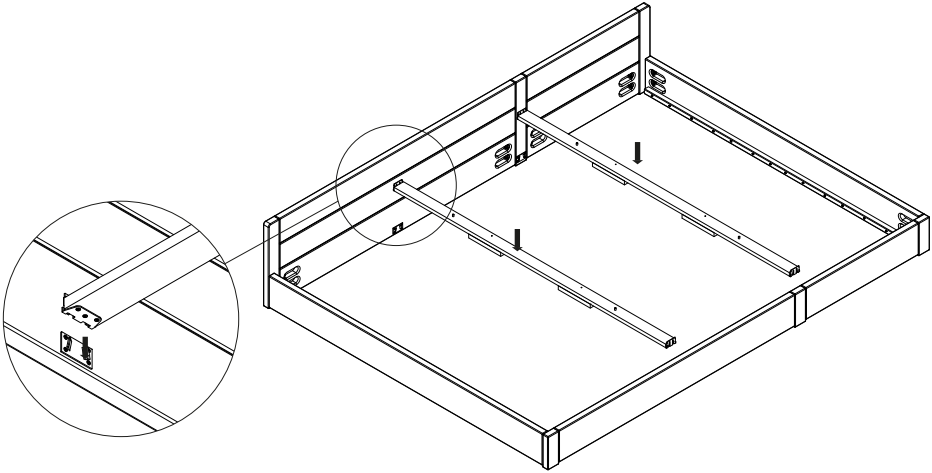

09

Falls du eine Ablage verwendest, tausche die Beine aus. Du hast beide Längen bereits mit dem Kauf der Ablage erhalten.

If you are using a shelf, replace the legs. You have already received both lengths with the purchase of the shelf.

Si tu utilises une tablette, échange les pieds. Tu as déjà reçu les deux longueurs lors de l'achat de la tablette.

Se si utilizza uno scaffale, sostituire le gambe. Con l'acquisto del ripiano avete già ricevuto entrambe le lunghezze.

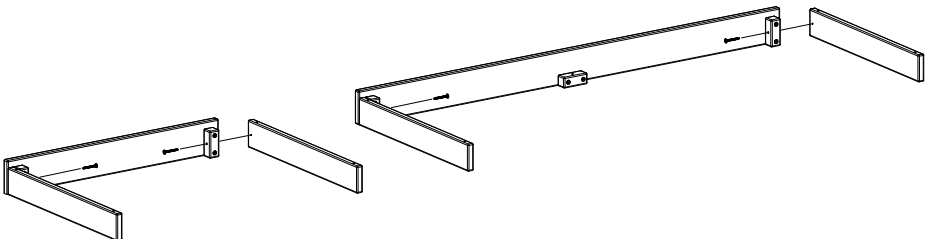

10

**Verschraube die Ablage  
wieder mit dem Kopfteil.**

**Screw the shelf to the  
headboard again.**

**Visse à nouveau la  
tablette à la tête de lit.**

**Avvitare nuovamente il  
ripiano alla testata.**

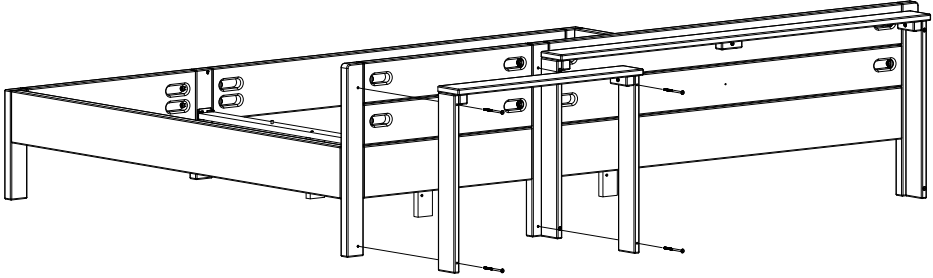



# Ehrenkind

## **Du brauchst Unterstützung?**

Besuche unser Serviceportal, scanne einfach den Code mit deinem Smartphone.

---

## **Need support?**

Visit our service portal, simply scan the code with your smartphone.



## **Ehrenkind**

formbench GmbH  
Ginsterweg 3  
74523 Schwäbisch Hall