

Lattenrost

Slatted frame | Grille à lattes | Telaio a doghe

Montageanleitung

assembly instructions | instructions de montage |
istruzioni di montaggio

Ehrenkind

Lieferumfang prüfen

1. Nimm die Einzelteile aus der Verpackung.
2. Prüfe, ob die Lieferung vollständig ist.
3. Prüfe, ob das Produkt, die Einzelteile oder das Zubehör Schäden aufweisen. Ist dies der Fall, benutze das Produkt nicht. Wende dich direkt an uns über das Serviceportal.

- 1 1× Seitenteil rechts
- 2 1× Seitenteil links
- 3 2× Querstrebe A
- 4 1× Querstrebe B
- 5 10× Kunststoff-Schieber
- 6 5× Latten kurz
- 7 24× Latten
- 8 4× Latten Schulterbereich
- 9 1× Textilband
- 10 10× Schraube (7 × 50)
- 11 2× Holzschraube

Bitte beachte die Hinweise
in der Montageanleitung!



Checking scope of delivery

1. Take the individual components out of the packaging.
2. Check whether the delivery is complete.
3. Check whether the product, the individual components or accessories are damaged. If this is the case, do not use the product. Contact us directly via our service portal.

- 1 1× Side piece right
- 2 1× Side piece left
- 3 2× Cross brace A
- 4 1× Cross brace B
- 5 10× Plastic slider
- 6 5× Slats short
- 7 24× Slats
- 8 4× Slats shoulder area
- 9 1× Textile strap
- 10 10× Screw (7 × 50)
- 11 2× Wood screw

Please note the information
in the assembly instructions!

Vérification du contenu de la livraison

1. Sortez les différentes pièces de l'emballage.
2. Vérifiez si la livraison est complète.
3. Vérifiez si le produit, les pièces détachées ou les accessoires présentent des dommages. Si tel est le cas, n'utilisez pas le produit. Contactez-nous directement via notre portail de services.

- 1 1×Partie latérale droite
- 2 1×Partie latérale gauche
- 3 2×Traverse A
- 4 1×Traverse B
- 5 10×Poussoir en plastique
- 6 5×Lattes courtes
- 7 24×Lattes
- 8 4×Lattes zone des épaules
- 9 1×Bande textile
- 10 10×Vis (7×50)
- 11 2×Vis à bois



Veuillez tenir compte des indications dans les instructions de montage !

Controllo della fornitura

1. Estrarre le singole parti dall'imballaggio.
2. Controllare che la fornitura sia completa.
3. Controllare se il prodotto, le singole parti o gli accessori sono danneggiati. In tale eventualità, non utilizzare il prodotto. Contattaci direttamente tramite il nostro portale di servizi.

- 1 1×Parte laterale destra
- 2 1×Parte laterale sinistra
- 3 2×Puntone trasversale A
- 4 1×Puntone trasversale B
- 5 10×Cursore in plastica
- 6 5×Listelli corti
- 7 24×Listelli
- 8 4×Listelli area della spalla
- 9 1×Cinturino in tessuto
- 10 10×Viti (7×50)
- 11 2×Viti per legno

Si prega di osservare nelle indicazioni istruzioni di montaggio!

Lattenrost montieren
Assembling the slatted frame

Assembler le grille à lattes
Montaggio del telaio a doghe

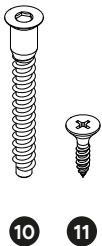
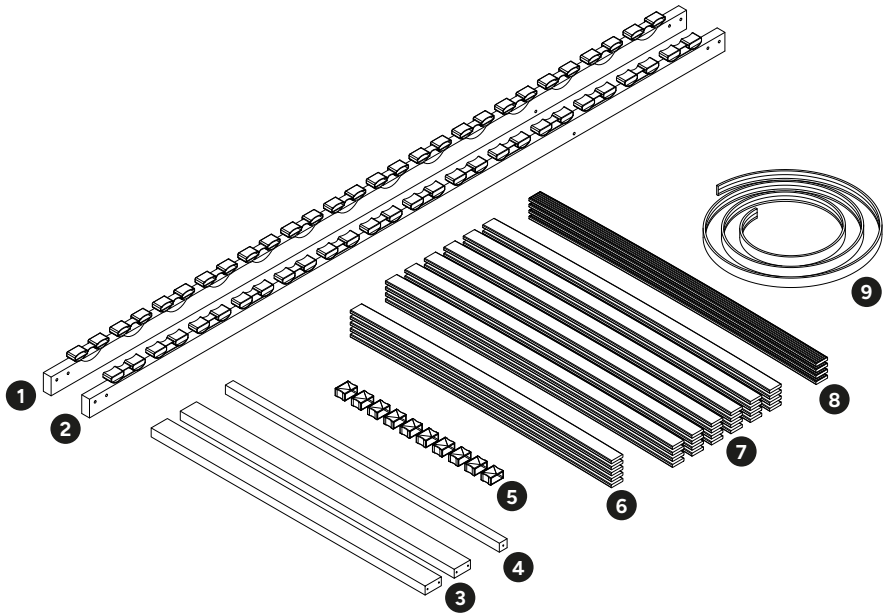

Schulterbereich
Shoulder area
Zone des épaules
Area della spalla

Hart ← → Weich
Hard ← → Soft
Dur ← → Doux
Duro ← → Morbido

Einstellbar
Adjustable
Réglable
Regolabile

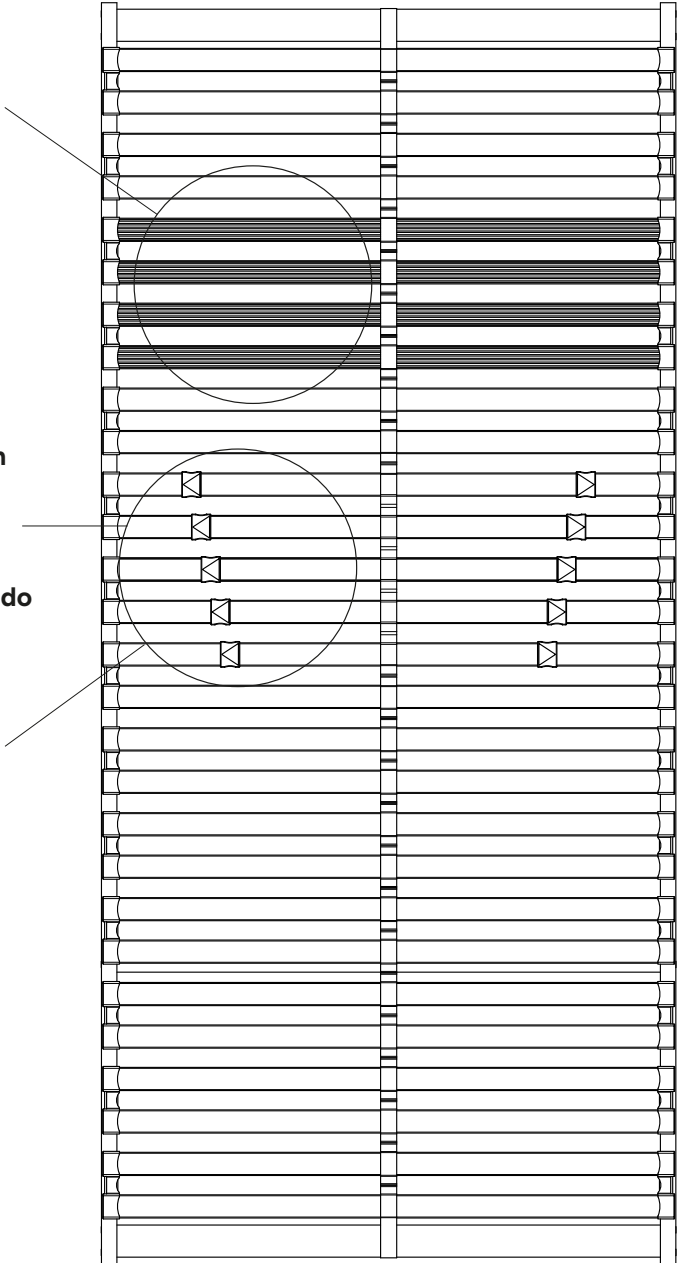

01

- 1× 1
- 1× 2
- 2× 3
- 1× 4
- 10× 10

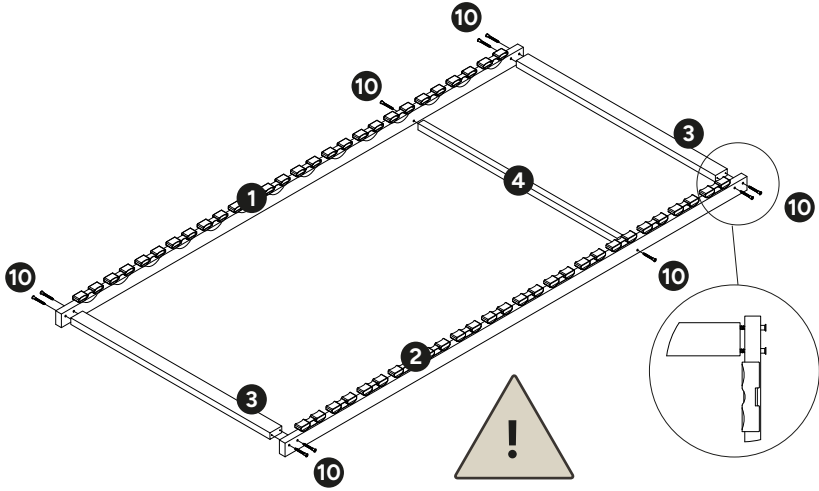

02

- 1× 5
- 1× 6
- 1× 7

5×

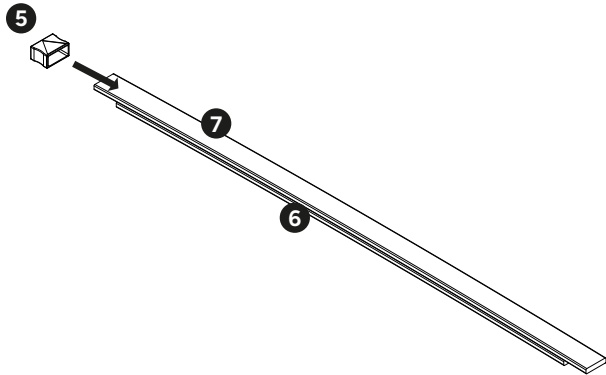

03

1×7

1×9

28×

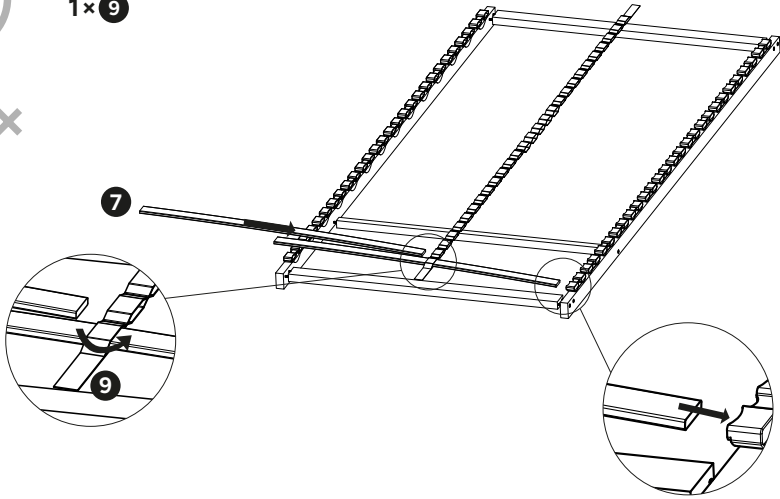

Zur Montage
an eine Wand
schieben

Push against a wall
for assembly

Pousser contre
un mur pour
l'assemblage

Spingere contro
una parete per il
montaggio

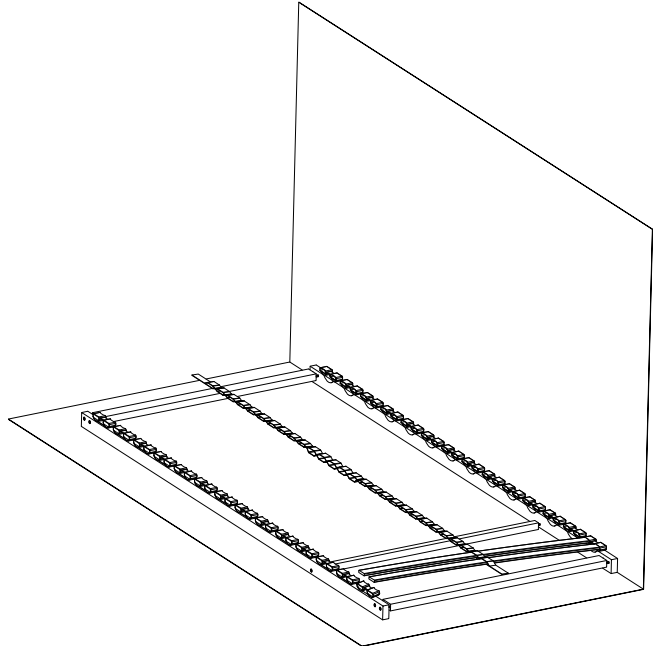

04

1x7

28x

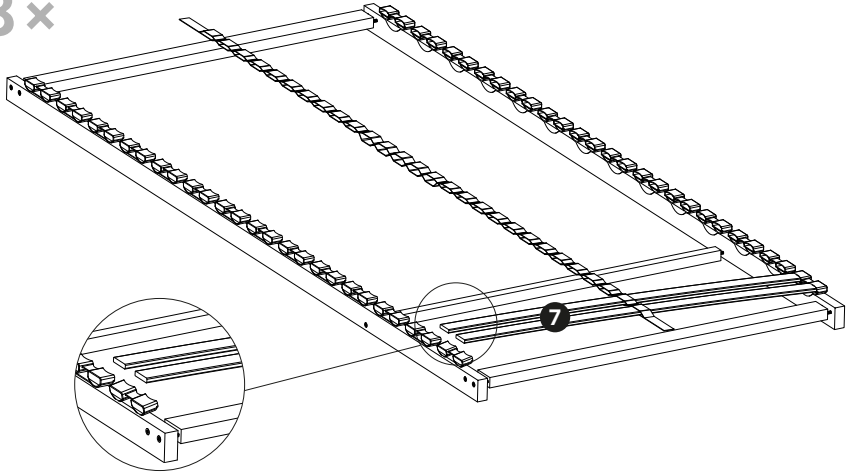

05

1x5

5x

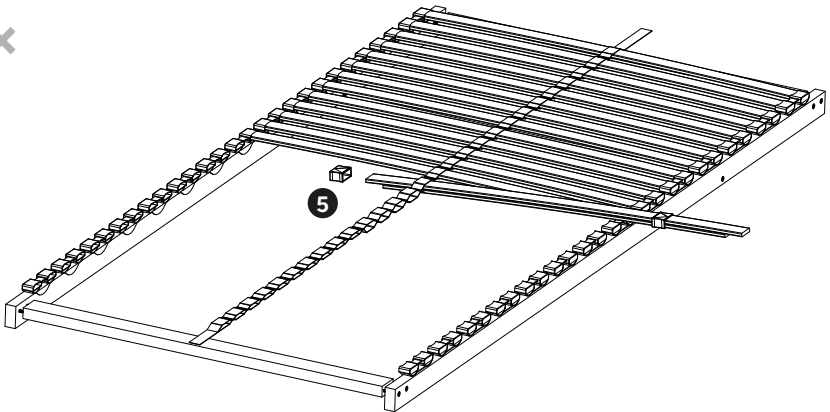

06

1x7

10x

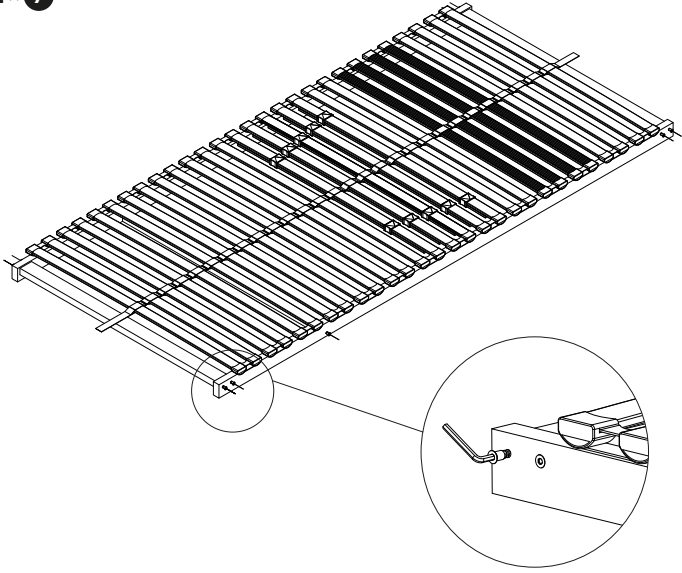

07

1x9

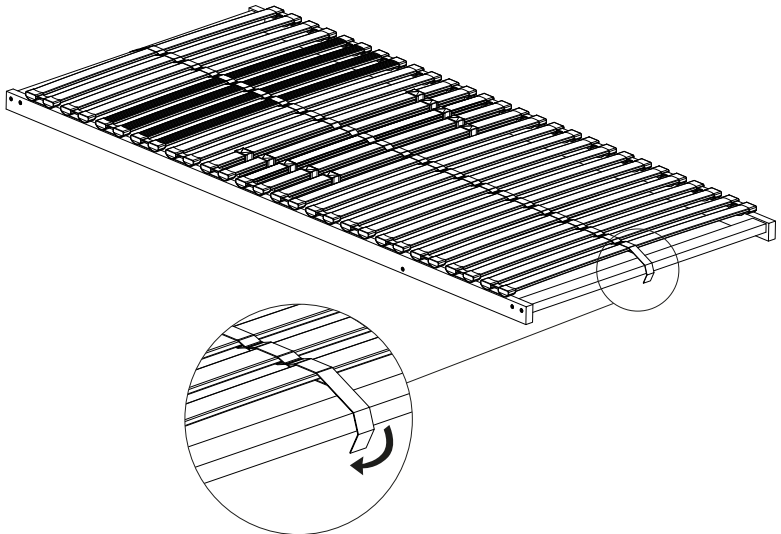

08

1x7

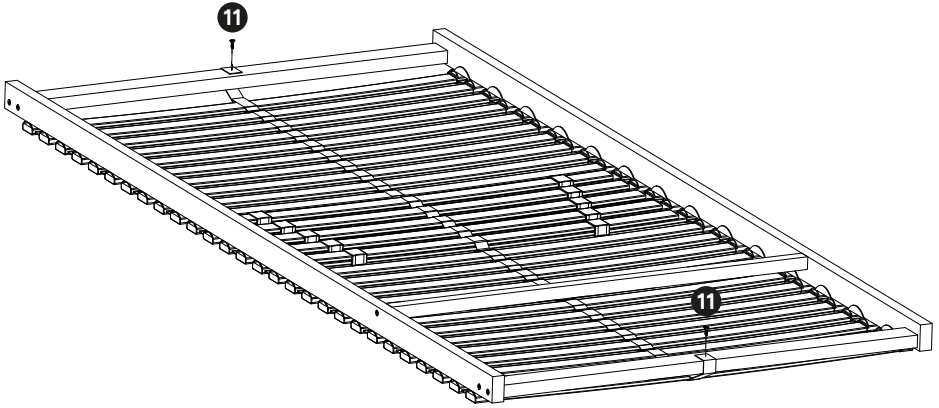

Ehrenkind

Du brauchst Unterstützung?

Besuche unser Serviceportal, scanne einfach den Code mit deinem Smartphone.

Need support?

Visit our service portal, simply scan the code with your smartphone.



Ehrenkind

formbench GmbH
Ginsterweg 3
74523 Schwäbisch Hall